



2020



# TABLE OF CONTENTS

|    |                                   |
|----|-----------------------------------|
| 4  | ABOUT US                          |
| 6  | STIFFLEX                          |
| 7  | STIFFLEX: FORMATS - DISPLAYS      |
| 8  | STIFFLEX COLLECTIONS              |
| 25 | STIFF                             |
| 28 | GIULIANO MAZZUOLI - WRITING TOOLS |
| 32 | OFFICINA                          |
| 44 | MOKA                              |
| 48 | NOBILE ITALIA                     |
| 52 | CASSIA                            |
| 56 | FORMULAPEN                        |
| 60 | OFFICINA ACCESSORIES              |
| 62 | WINDOW DISPLAYS                   |
| 64 | CORPORATE GIFTS                   |



1



2

SOME OF OUR FRIENDS:

- 1 Lapo Elkann - Moka Fiat
- 2 Russell Crowe - Manometro Chronograph
- 3 Cesare Prandelli - Manometro
- 4 Elle Macpherson - Manometro
- 5 Paul Newman - Contagiri



3



4



5

# 3•6•5®

3•6•5® manufactures and markets writing products that express the creative genius of the designer Giuliano Mazzuoli who has for some time now dedicated himself to the realization of prestigious wristwatches that are sought after and worn by many celebrities. They are pens, planners, and notebooks with clean and original ergonomic forms that perfectly adapt to every occasion with taste and elegance. Produced and assembled in Italy, the products by 3•6•5 are unique and represent a true example of the artisanal quality of products made in Italy. One needs to only think of the patented *Stifflexible* cover system, created in 1997 from

the desire to recuperate an ancient binding technique observed in a prestigious Florentine library by Giuliano himself: a sturdy cover that holds many pages together and is easy to consult. It's an ancient process that has been modernized and adapted to the most innovative artisanal techniques that combines the quality of the materials with an extraordinary flexibility and resistance to wear.

The 3•6•5 product lines are able to combine great precision to the passion of master artisans who like tailors from old times are able to "sew an outfit" to measure and make it suitable for any occasion.



Advertising Campaign for Giuliano Mazzuoli's Manometro  
Photo: Oliviero Toscani



Historical Notes  
collection

stifflexible  
made in italy



Calaca

stifflexible  
made in italy



stifflexible  
made in italy

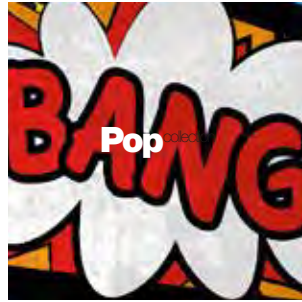

Pop  
collection



stifflexible  
made in italy



Vintage Surfing  
collection

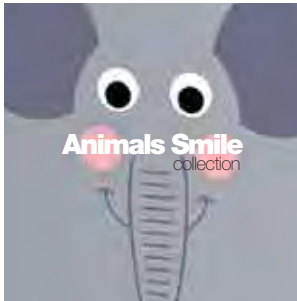

Animals Smile  
collection



stifflexible  
made in italy



Underground  
collection



stifflexible  
made in italy



stifflexible  
made in italy



Mrs. Crocodile  
collection



stifflexible  
made in italy

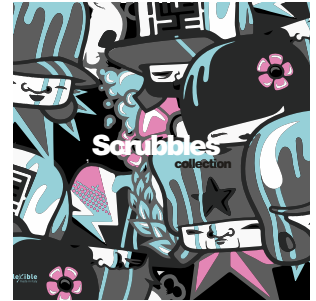

Scrubbles  
collection



Icon



stifflexible  
made in italy

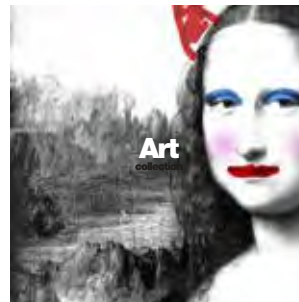

Art  
collection



stifflexible  
made in italy



stifflexible  
made in italy



Gasoline  
collection



stifflexible  
made in italy

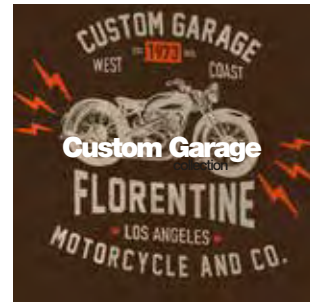

Custom Garage  
collection



An innovative system patented by Giuliano Mazzuoli, the designer and founder of the company, is at the foundation of the new **Stifflex** collections that are born from the talent and the creativity of a number of young graphic designers who by giving a free outlet to their fantasies have conceived the covers for

the new collections of notebooks in the *Urban Series*, *Vintage Surfing*, *Surfside*, *Art*, *Calaca*, *Skull*, *Chess*, *Scrubbles*, *Underground*, *Cocktail*, *Camouflage*, *Fresh Fruit*, *Historical Notes*, *Pop*, *Campbook*, *Fluo Love*, *Fluo Marilyn*, *Wild Pearl*, *Mrs. Crocodile*, *Animals Smile*, *Icon*, *Flora*, *New Fresh Fruit*, *Custom Garage*, *Gasoline* collections.

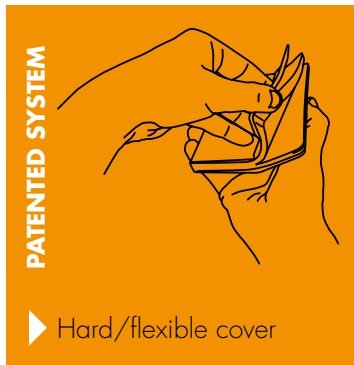

▶ Hard/flexible cover

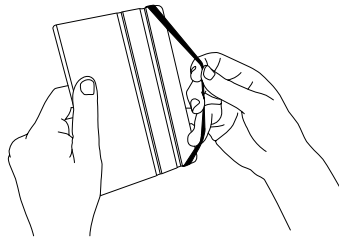

▶ Elastic closure

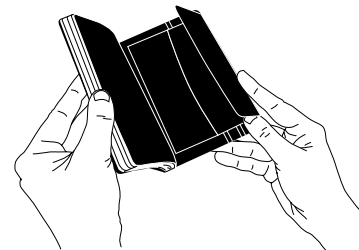

▶ Pocket/Bookmark

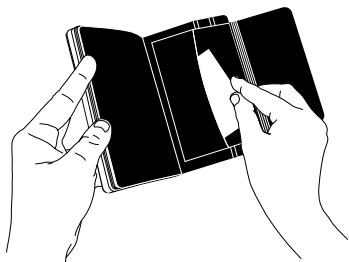

▶ Document holder pocket

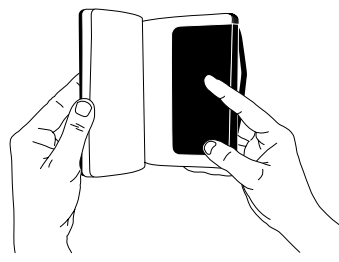

▶ Bookmark

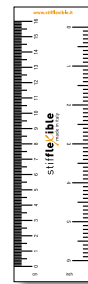

Every notebook comes with a ruler/bookmark

# FORMATS

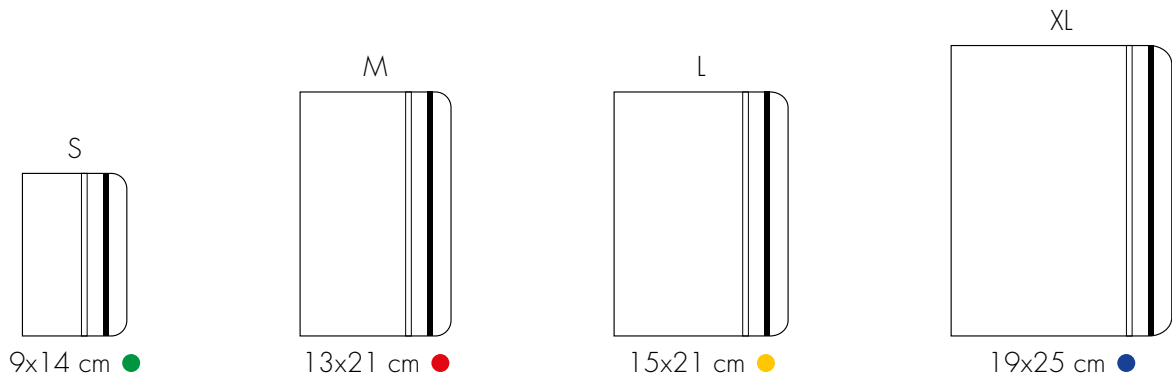

The notebooks are made with uncoated ivory-colored paper of 80 g. in the 9x14 cm, 13x21 cm, 15x21 cm and 19x25 cm formats.

- 9x14 cm: comprised of 144 pages of which 96 are lined, 32 are blank, and 16 are graphed.
  - 13x21 cm 15x21 cm, 19x25 cm: comprised of 192 pages of which 144 are lined, 32 are blank, and 16 are graphed.
- The graphed pages are perforated and easily detachable.  
The product is certified FSC®.

# DISPLAYS

The *Stifflexible* displays are supplied already assembled and are made in alveolar cardboard in a havana brown color so that the entire production maintains unaltered the standards of environmental sustainability and respect for the environment in which the company as always based its policies.



EXPO1 S

Counter display (9x14 cm)

**Measurements:** cm 34x29x27

**It can contain:** 36 pieces, 9x14 cm



EXPO2 M

Counter display (13x21 cm and/or 15x21 cm)

**Measurements:** cm 52x29x34

**It can contain:** 36 pieces, 13x21 cm and/or 15x21 cm



EXPO3 L

Floor display

**Measurements:** cm 60x25x185

**It can contain:** 100 pieces, 9x14 cm  
60 pieces, 13x21 cm  
40 pieces 15x21 cm  
30 pieces 19x25 cm  
230 assorted pieces in total

# URBAN SERIES

---



NEW YORK CITY

093M (13x21)



MANHATTAN

094M (13x21)



BROOKLYN

095M (13x21)

# URBAN SERIES

---



TESTACCIO

096M (13x21)



BRERA

097M (13x21)



GINZA

098M (13x21)

# URBAN SERIES

---



MARAIS

099M (13x21)



CAMDEN TOWN

100M (13x21)



# VINTAGE SURFING

---



CALIFORNIA BLUE

001S (9x14)  
001M (13x21)



CALIFORNIA RED

002S (9x14)  
002M (13x21)



CALIFORNIA BLACK

003S (9x14)  
003M (13x21)

# VINTAGE SURFING

---



ADVENTURE ORANGE

004S (9x14)  
004M (13x21)



ADVENTURE RED

005S (9x14)  
005M (13x21)



ADVENTURE GREEN

006S (9x14)  
006M (13x21)

# VINTAGE SURFING

---



SURF RIDER BLUE

007S (9x14)  
007M (13x21)



SURF RIDER RED

008S (9x14)  
008M (13x21)



SURF RIDER ORANGE

009S (9x14)  
009M (13x21)

# SURFSIDE

---



# ART

---

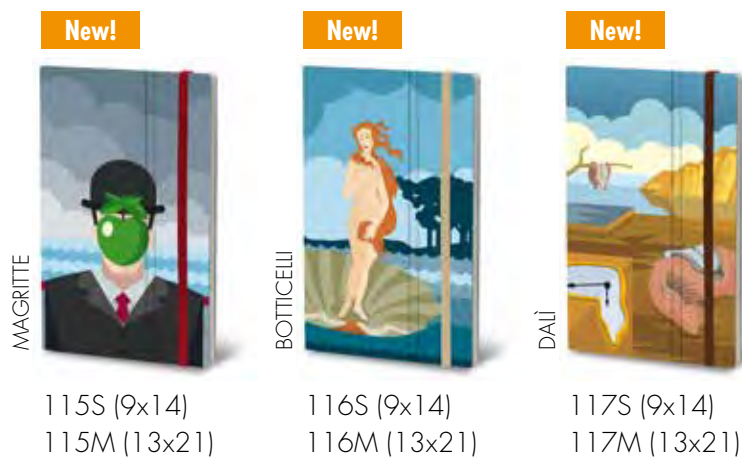

# ART

---



# CALACA

---



# CALACA

---



# CALACA

---



# SKULL

---



# CHESS

---



# SCRUBBLES

---



# UNDERGROUND - New York

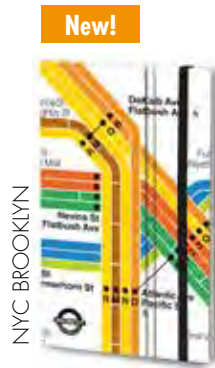

123S (9x14)  
123M (13x21)



124S (9x14)  
124M (13x21)



125S (9x14)  
125M (13x21)

# UNDERGROUND



056S (9x14)  
056M (13x21)  
056XL (19x25)



057S (9x14)  
057M (13x21)  
057XL (19x25)



058S (9x14)  
058M (13x21)  
058XL (19x25)

# UNDERGROUND



059S (9x14)  
059M (13x21)  
059XL (19x25)



060S (9x14)  
060M (13x21)  
060XL (19x25)

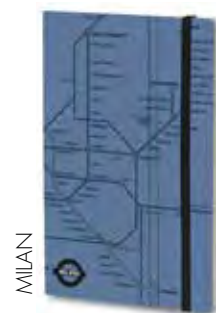

061S (9x14)  
061M (13x21)  
061XL (19x25)

# COCKTAIL

---



# CAMOUFLAGE

---

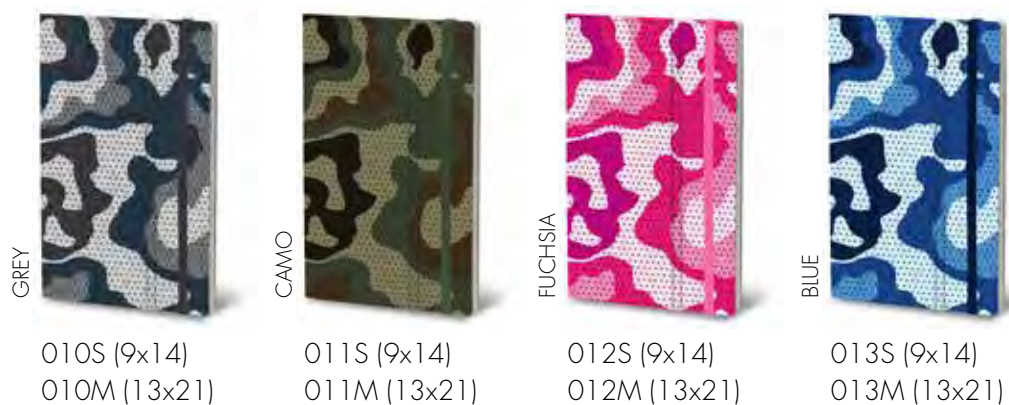

# FRESH FRUIT

---



# HISTORICAL NOTES

---



# HISTORICAL NOTES

---

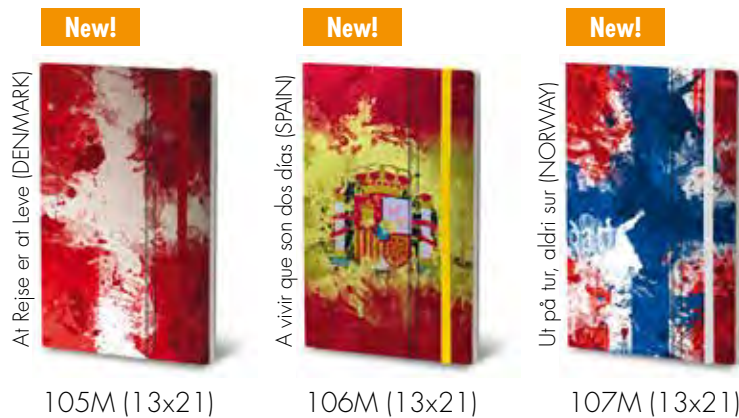

# HISTORICAL NOTES

---



# HISTORICAL NOTES

---



025M (13x21)



026M (13x21)



027M (13x21)



028M (13x21)

# HISTORICAL NOTES

---



029M (13x21)



030M (13x21)



031M (13x21)



032M (13x21)

# HISTORICAL NOTES

---



033M (13x21)



034M (13x21)



035M (13x21)



036M (13x21)



# POP

---



# POP

---



# POP

---



# CAMPBOOK



# FLUO LOVE



# FLUO MARILYN

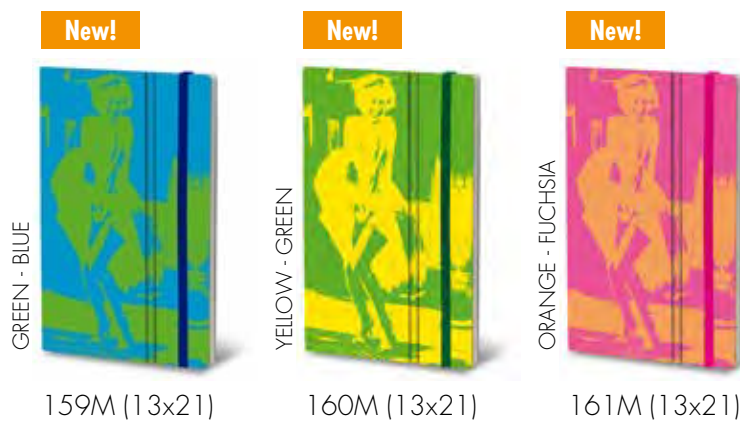

# WILD PEARL

---



# WILD PEARL

---



# MRS. CROCODILE

---

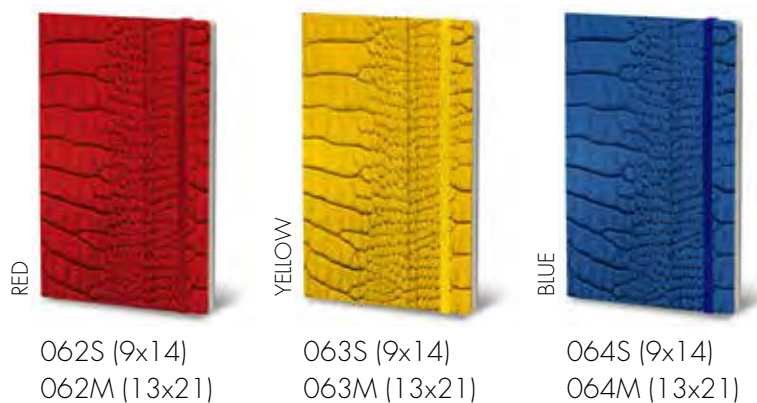

# WILD PEARL

---



# WILD PEARL

---

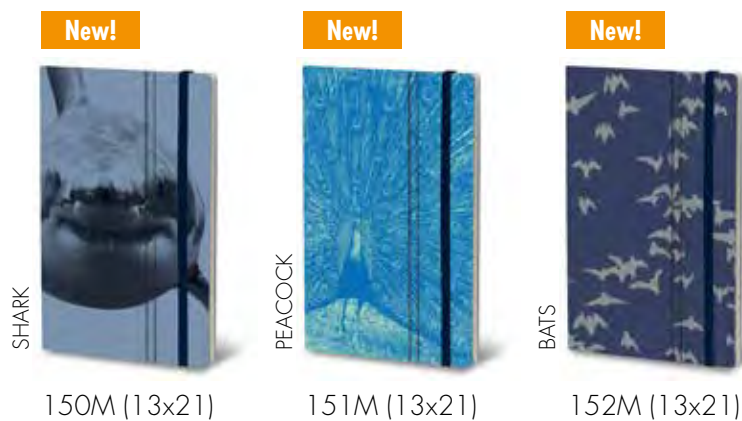

# MRS. CROCODILE

---

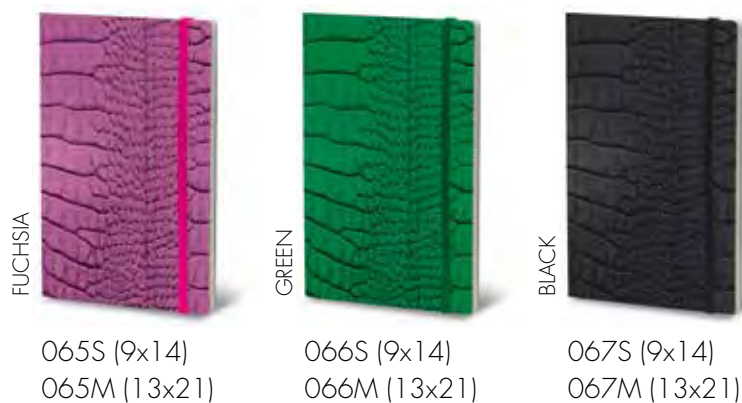

# ANIMALS SMILE

---



FROG

044M (13x21)



COW

045M (13x21)



BEAR

046M (13x21)

# ANIMALS SMILE

---



RABBIT

047M (13x21)



ELEPHANT

048M (13x21)



PENGUIN

049M (13x21)

# ICON

---



CAPTAIN SHIELD

068M (13x21)



LIGHTNING

069M (13x21)



FLAME

070M (13x21)

# FLORA

---



# FLORA

---



# ICON

---



# NEW FRESH FRUIT

---



# NEW FRESH FRUIT

---



# CUSTOM GARAGE

---



# GASOLINE

---



# GASOLINE

---



# CUSTOM GARAGE

---





3.6.5



The name for the new *Stifflex* collection, with its essential and harmonious design, comes from the shortening of the name *Stifflex*.

It's a more classic version of our notebook that enhances the value of tradition and enriches it with new elements. A hard cover with a balanced shade and the inside pages either blank

or lined are combined with an environmentally friendly pencil with an eraser made with recycled and recyclable material. Available in the *Basic* and *Leatherlike* collections, the notebooks in this line adapt perfectly to every occasion and above all are perfect for those who enjoy habits that respect values from other times.

## FORMATS

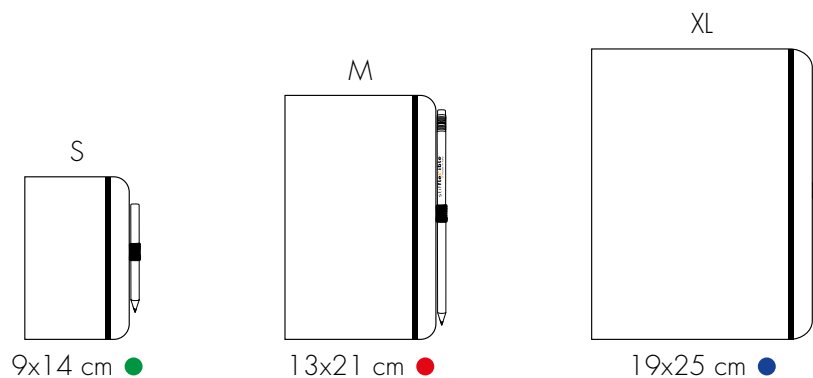

The notebooks in this collection are made with 80 g. uncoated white paper. They are available in the 9x14 cm, 13x21 cm, and 19x25 cm formats made up of 144 pages. Every notebook comes with a pencil and is FSC® certified.

# BASIC

## HARD COVER NOTEBOOK WITH PENCIL



26



Ruled sheets



Blank sheets



BLACK

aR001S (9x14)  
aR001M (13x21)

RED

aR002S (9x14)  
aR002M (13x21)

BLUE

aR003S (9x14)  
aR003M (13x21)

YELLOW

aR004S (9x14)  
aR004M (13x21)

bR001S (9x14)  
bR001M (13x21)

bR002S (9x14)  
bR002M (13x21)

bR003S (9x14)  
bR003M (13x21)

bR004S (9x14)  
bR004M (13x21)

# LEATHERLIKE

## HARD COVER NOTEBOOK WITH PENCIL



Ruled sheets



BLACK

aR005M (13x21)

BROWN

aR006M (13x21)

LIGHT BROWN

aR007M (13x21)

DOVE GREY

aR008M (13x21)



### OUR PRODUCTION:

- Graphics production
- Printing
- Binding
- Production of stationery products







# GIULIANO MAZZUOLI

## WRITING TOOLS

Made from a solid bar of aluminum, the Giuliano Mazzuoli pens are made through an elaborate lathe and milling process done through the use of state-of-the-art machinery. After that every single structural component is carefully finished and assembled by hand. The high standards of quality and a careful selection of the raw materials guarantee in each product a nearly eternal use.

Fountain pens, ballpoint pens and pencils that don't follow the classic canons for writing and reveal an authentic identity that combines planning research, functionality and aesthetics with a selection of modern colors. Above all, every

product comes to life from the desire to relive and remember values from the past and from family experiences resulting in a collection of small "works of art" that also take inspiration from discoveries and exceptional inventions of Italian national history. A clean design, original shapes, prestigious materials and workmanship make it so that every Giuliano Mazzuoli pen is a unique artisanal jewel where every detail is looked after.

The entire line of writing instruments is produced in every phase in the heart of Tuscany through selected raw materials and the expertise of local labor creating a true example of made in Italy craftsmanship.



1 1923, Tavarnelle Val di Pesa - Officina Meccanica Renato Bacci

2 1925, Flora Bacci and Galliano Bacci

3 1920, Renato Bacci with a bicycle that he manufactured



2



3

## GIULIANO MAZZUOLI



« **W**hat do bicycles have to do with pens? Nothing. There is only a memory that makes me feel a particular bond with the Officina line (“officina” means mechanical workshop in Italian). The picture is from 1923 and the little girl in the picture is my mother. My grandfather Renato had a mechanical workshop with lathes and cutters with which he built handcrafted bicycles. At the beginning of the 1950s, with the advent of motorcycles in a hilly terrain like ours, the activity became obsolete and ended. A few years later, when I was about ten

years old, I found and kept an old wooden box with metal objects that had a strange form. For some years afterwards it was a treasure that I tried keeping secret. In November 1999 I found myself in a modern mechanical workshop and while I was looking around I saw the same objects. Forty years later they still fascinated me with their beautiful shapes and I wanted to let others appreciate them not as mechanical tools and so “Officina, Writing Instruments” were born. »

*Giuliano Mazzuoli*

# OFFICINA



## Micrometer

P01MN01 BP  
P01MS01 FP



## Thread

P01MN05 BP  
P01MS05 FP



## Knurler

P01MN07 BP  
P01MS07 FP

## DESIGN

---

Micrometer  
Thread  
Knurler







COLORS

Brushed chrome

AVAILABLE IN

Micrometer, Thread and Knurler:  
Ballpoint  
Fountain Pen



# OFFICINA END MILL – COLOR



P01MN03 BP  
P01MS03 FP



P01MN03C BP  
P01MS03C FP



P01MN03D BP  
P01MS03D FP

DESIGN

---

End Mill

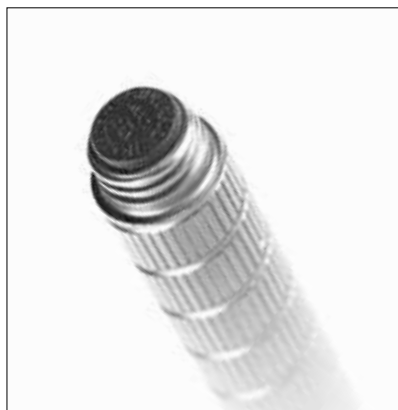



COLORS

Brushed chrome  
Gunmetal  
Vintage ivory

AVAILABLE IN

Ballpoint  
Fountain Pen



# OFFICINA END MILL - BICHROME



P01MN03R BP  
P01MS05R FP



P01MN03B BP  
P01MS05B FP



P01MN03V BP  
P01MS05V FP

DESIGN

---

End Mill





COLORS

Red/polished chrome  
Blue/polished chrome  
Green/polished chrome

AVAILABLE IN

Ballpoint  
Fountain Pen



# OFFICINA CASSETTA

We called this version of Officina with the name "Cassetta" because just like in a toolbox case where you find various tools, countless accessories are found even in this package: "Easy Flow" ballpoint, colored ballpoint (in three colors), 2 mm pencil that exalt the functions of the pen. In the packaging are also four 2 mm leads (red - green - yellow - blue), a pencil sharpener, a pencil eraser, and an elegant leather pen holder available in three different colors.



- PO1MK01 MICRO CHROME
- PO1MK05 THREAD CHROME
- PO1MK07 KNURLER CHROME
- PO1MK03 MILL CHROME
- PO1MK03C MILL GUN METAL CHROME
- PO1MK03D MILL VINTAGE IVORY



## DESIGN

Micrometer  
Thread  
Knurler  
End Mill

## COLORS

Micrometer, Thread and Knurler:  
Brushed chrome

End Mill:  
Brushed chrome  
Gunmetal  
Vintage ivory



#### LEATHER PEN HOLDER

---

Tabacco  
Orange  
Yellow

#### FUNCTIONS

---

Ballpoint "Easy Flow"  
Ballpoint (in three colors)  
Pencil (2 mm)  
Colored Leads (in four colors)



# OFFICINA QUATTRO TEMPI XL

The Quattro Tempi model is a product that can be easily convertible into different functions:  
- roller - colored rollers (in four colors) - 5.5 mm graphite pencil - fountain pen. In the packaging are five 5.5 mm pencil leads (graphite - blue - red - yellow - green), a fountain pen converter, a fountain pen ink cartridge, a pencil eraser, and a pencil sharpener. In the photograph below we show how this particular model is presented in the gift packaging and the pens that can be assembled from the parts found inside the packaging.

40  
OFFICINA



P010403



DESIGN

End Mill

COLORS

Brushed chrome



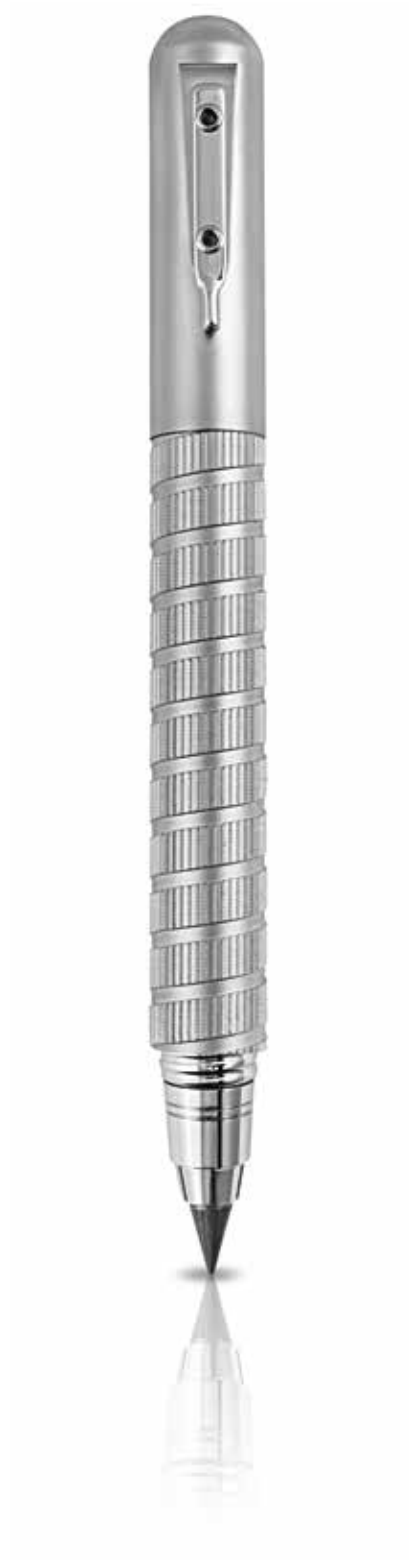

## FUNCTIONS

Roller

Colored rollers (in four colors)

Fountain pen

Graphite Pencil (5.5 mm)

5.5 mm leads in graphite + four colors  
(blue, red, yellow, and green)



# OFFICINA LIMA

The Lima pen is inspired from the round file (lima in Italian) used by blacksmiths. It is a pen with three different writing functions (black ball point - red ball point - 0.5 mm pencil). Other accessories like the orange color highlighter, touchscreen stylus, a pencil eraser, and a kit of 0.5 mm pencil leads are also included in the packaging.

42  
OFFICINA



PO1L310 CHROME  
PO1L320 BRUSHED  
PO1L330 RED  
PO1L340 BLACK





COLORS

- Brushed chrome
- Black
- Red
- Polished chrome

FUNCTIONS

- Black ballpoint
- Red ballpoint
- Pencil (0.5 mm)
- Touchscreen stylus
- Orange highlighter



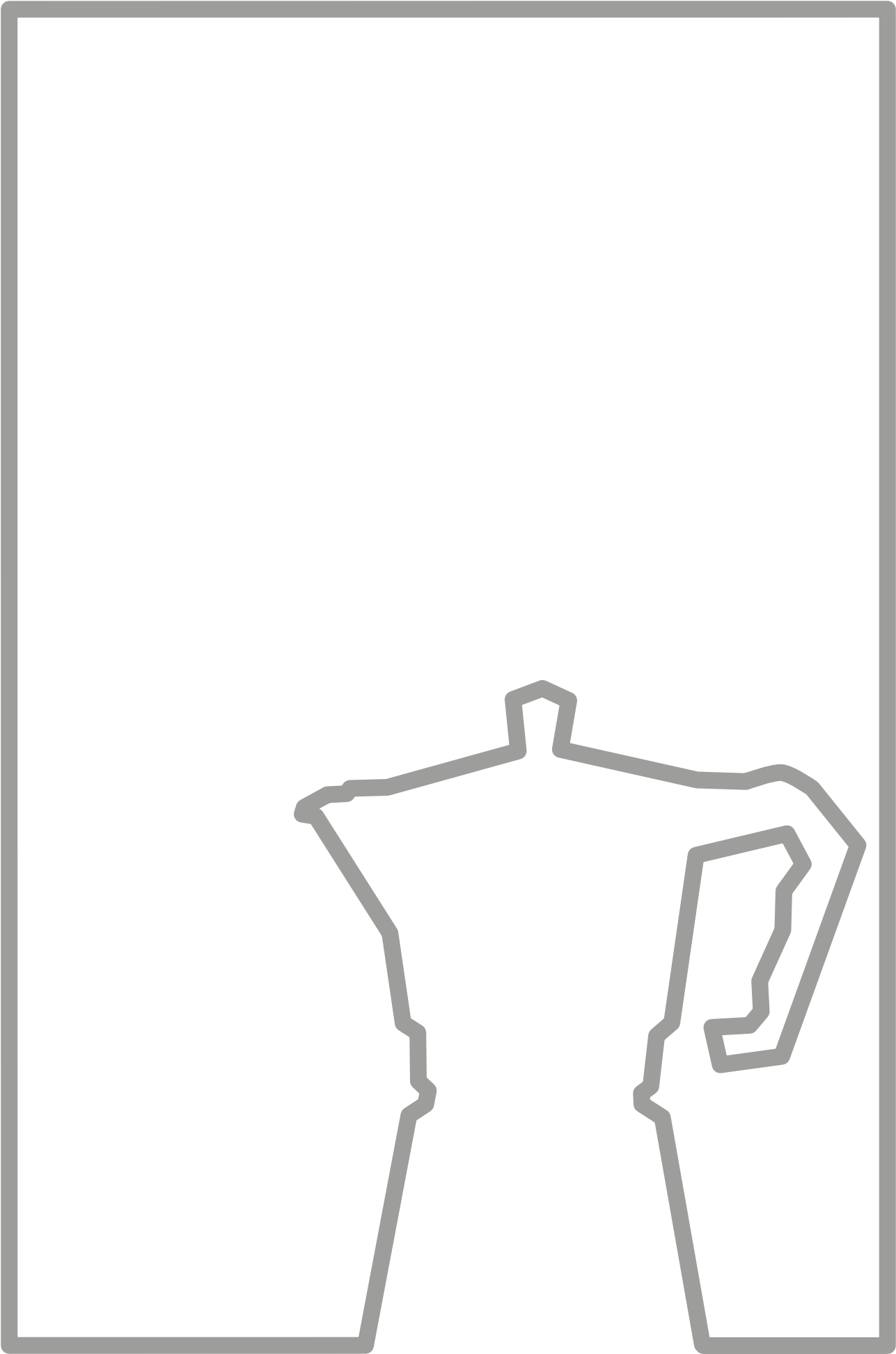

GIULIANO MAZZUOLI

# MO KA

« With the Officina line of pens I attracted the attention of the most important people in the world of pens. Part of the success of those pens is also due to the country I come from. It is because I am Italian and I am part of the most important design culture in the world that I had to present a new pen. I thought it was impossible, but it all happened during a telephone call. I was doodling with my pencil when I interrupted my telephone call and said, "sorry, but I have to go ... I designed my new pen." I realized it was the coffee-maker only after I had drawn it. The inspiration came at the right time because even in this pen there is a memory from my youth. The so-called "American kitchens" hadn't become popular yet in Italy. In my grandmother's huge but minimally decorated kitchen there were four or five different size espresso-makers hanging on a wall above

a shelf. They were the only decorative elements in the kitchen and I had never seen my grandmother make coffee with them. She polished them every day. This was in the 1950s, the time in which the Moka, designed and produced by Alfonso Bialetti in 1930, started to become well known all over the world. It reached places in the world where uses and customs regarding beverages were completely different from ours and it was used as a decorative accessory just like my grandmother had done. I too see in this everyday object made up of two containers that screw into each other a masterpiece of design. Nothing is more difficult to design than simplicity and I wanted to dedicate a writing instrument to this jewel of design that is more than eighty years old now. »

*Giuliano Mazzuoli*



# MOKA

The MOKA pen is available in fountain pen and "pressurized" ballpoint versions.





MKS1101 BP  
MKS11S1 FP



MKS1109 BP  
MKS11S9 FP



MKS1102 BP  
MKS11S2 FP



MKS1104 BP  
MKS11S4 FP

COLORS

Natural aluminum  
Red  
Vintage ivory  
Black

AVAILABLE IN

Ballpoint  
Fountain pen





1926 - Colonel Umberto Nobile and his little dog Titina



1926 - Amundsen-Ellsworth-Nobile, Rome - Alaska, "Norge" Expedition



1928 - Italia parked at Vadsö



1928 - Italia hangar in Stolp



May 25, 1928 - Dropping of the flag and the Cross on the pole



The Red Tent



The Red Tent, July 12, 1928 - The Krassin at the red tent



**UMBERTO NOBILE** (Lauro, Avellino 1885 - Rome 1978) was one of the key figures in the history of flight.

A General in the Italian Royal Air Force, Nobile designed air ships all over the world, but he is mostly known for having flown across the North Pole twice. The first time was in 1926 at the request of Norway with the air ship NORGE, which he designed and commanded. The second time was in 1928 on an entirely Italian expedition aboard the air ship ITALIA. This last expedition ended dramatically when the ITALIA crashed into the ice due to adverse meteorological conditions, and the survivors were rescued after forty-eight days spent in the legendary "Red Tent."

The event and the subsequent fiery controversy tarnished Nobile's fame, and after being accused by the fascist regime he decided to voluntarily go into exile and move to the Soviet Union where he worked for five years building air ships.

At the end of 1936 he decided to go back to Italy, but due to political and personal difficulties he decided to leave again after accepting an offer to work in the United States.

After the fall of Fascism in Italy in July of 1943, he moved back to Italy definitively and from

1946 to 1948 was an independent representative in the Constituent Assembly of Italy. His role in history and his accomplishments have been re-evaluated over the years and Nobile has been recognized for what he really was: a genius engineer, an able aviator, and an untiring explorer.

Talent, inventiveness, and passion were the key personality traits of Nobile; this combined with the fact that this extraordinary individual was from the Italian hinterland moved Giuliano Mazzuoli to create a pen in his honor. The NOBILE ITALIA commemorates this Italian genius through a synthesis of contemporary creativity and the high quality of the materials used.

The exclusive shape, inspired by the air ship ITALIA, makes this writing instrument more pleasant and functional to use.

The NOBILE ITALIA is born from the talent of Italian craftsmen. It is an original product with a modern design whose inspiration comes from a glorious past.

The care taken in the details and the selection of the materials make the NOBILE ITALIA a collector's pen, but the pleasure of the feel of its form (when taking it out from a bag or the pocket of a jacket), grip, and decisive writing stroke, make it unforgivable to not use it every day.

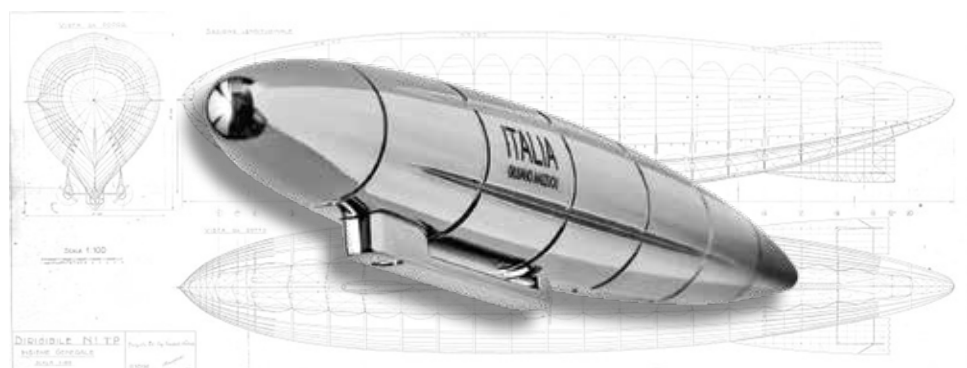

# NOBILE ITALIA

The Nobile Italia pen is available in 4 colors. In addition to the pen with ballpoint "Easy Flow" refill, the packaging contains: 0.7 mm pencil, 3 colored ballpoint refills, and a pencil eraser.

50  
NOBILE ITALIA



*"The Nobile Italia pen is dedicated to all the men who made an extraordinary enterprise possible. They were men of courage who taught us that no objective is impossible to achieve."*



IT04 BLACK



IT01 BRUSHED  
CHROME



IT03 AVIATOR



IT02 POLISHED  
CHROME

COLORS

- Black
- Brushed chrome
- Aviator blue
- Polished chrome

FUNCTIONS

- Ballpoint "Easy Flow"
- Pencil (0.7 mm)
- Ballpoint (in three colors)





GIULIANO MAZZUOLI

# CASSIA

The Cassia is a road that is like a work of art. It's a road that has its origins in the distant 154 B.C., the year that the Via Cassia was built, and it celebrates and represents the Italian culture.

It begins in Rome at the Milvian Bridge and it goes all the way to Florence finishing on Ponte Vecchio, crossing places like the Bolsena Lake, the Crete Senesi, the Val d'Orcia, and Chianti, which make Italy well-known throughout the world. With the Cassia we wanted to pay

tribute to this beautiful road where Giuliano Mazzuoli's grandfather had his bicycle workshop in Tavarnelle Val di Pesa at km 264 (there are in fact 264 kilometers to Rome and 36 km to Florence).

Cassia is an Italian pen with an unmistakable style that brings us back to the era of Italian Modernism. The primary material is always aluminum. The ergonomic grip, the elegant but rigorous styling with a decoration at the top make this pen a symbol of Italian style.

# CASSIA

The Cassia pen is available in 3 colors. In addition to the pen with ballpoint "Easy Flow" refill, the packaging contains: 0.7 mm pencil, 3 colored ballpoint refills, a pencil eraser, and a kit of rubber rings in 6 different colors.

54  
CASSIA





PC264A3  
BRUSHED  
CHROME



PC264A2  
RED



PC264A1

COLORS

---

Brushed chrome  
Red  
Black

FUNCTIONS

---

Ballpoint "Easy Flow"  
Pencil (0.7 mm)  
Ballpoint (in three colors)  
Colored rubber ring kit



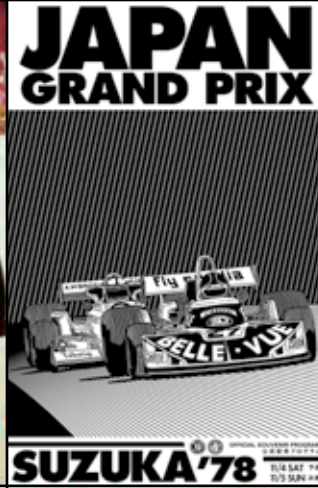



GIULIANO MAZZUOLI

## Formulapen

From Giuliano Mazzuoli's passion for automobiles and automobile racing comes the FORMULAPEN, whose lines recall the racing cars of the 20th Century.

Even the selection of the colors recall the competitions from the beginning of the 1900s in which a color was assigned to the automobiles from each nation participating in the world competition, "formula gran prix." Italy had "Racing Red" (Alfa Romeo, Maserati, and

Ferrari). France had blue, the "Blue of France" (Bugatti). Great Britain had green, "British Racing Green" (Jaguar, BRM, and Aston Martin). Germany had white (Mercedes, Autounion, and BMW) that subsequently transformed to silver not for aesthetic reasons, but purely for competitive reasons since without paint the cars were lighter in weight. This is where the name "Silver Arrows" comes from for the German automobiles.



# FORMULAPEN

The Formulapen is available in 4 colors. In addition to the pen with ballpoint "Easy Flow" refill, the packaging contains: a 0.7 mm pencil, 3 colored ballpoint refills, and a pencil eraser.





FP004  
BRITISH  
RACING  
GREEN



FP002  
BLUE



FP001  
RACING  
RED



FP003  
SILVER  
ARROW

## COLORS

---

British Racing Green  
Blue of France  
Racing Red  
Silver Arrow

## FUNCTIONS

---

Ballpoint "Easy Flow"  
Pencil (0.7 mm)  
Ballpoint (in three colors)



# OFFICINA ACCESSORIES

The Officina line, in addition to the "Writing Tools," expands its product line introducing 5 gift accessories that maintain intact and in a coherent way its creative line.



1 365KEY



2 365TWIN



3 365CLIP

## ACCESSORIES

---

- 1 Key Chain
- 2 Nut & Bolt cufflinks
- 3 Hinge Money Clip



## MANOMETRO TABLE CLOCK

Giuliano Mazzuoli's Manometro wristwatch is represented as a table clock in this version. The simple and essential design, and the clean dial with large numerals make the object original and elegant, as well as a perfect gift idea.

IGMP02

### TECHNICAL CHARACTERISTICS

**Case:** cylindrical (316L) steel case with a polished finish; the back is closed with 6 screws.

**Crown:** in steel positioned at 2 o'clock.

**Dial colors:** black or ivory.

**Functions:** hours, minutes, and seconds.

**Mechanism:** Swiss Movement ISA caliber 2331/103.

**Dimensions:**

61 mm (3h-9h) x 58 mm (12h-6h);

Case height: 22 mm.

**Weight:** 225 grams.

**Battery:** 66 months duration.



GMP01

61  
OFFICINA ACCESSORIES

## MECHANICAL BEARING PAPER WEIGHT

### COLORS

|          |          |
|----------|----------|
| Gunmetal | 365CUSC2 |
| Steel    | 365CUSC1 |

### CHARACTERISTICS

Metal  
ø 70 mm



# WINDOW DISPLAY MATERIAL



62 WINDOW DISPLAY MATERIAL

## MO KA



nobileitalia



**Formula**pen



# CORPORATE GIFTS

The entire Giuliano Mazzuoli Writing Tools collection can be personalized with the logo or the graphics of your company. The personalization of the pen can be done through three systems: laser engraving, diamond-point engraving, or it can be milled and enameled. The packaging of the pen can be personalized with institutional photographs or graphics so as to create an object that coordinates itself perfectly with your company image. Many prestigious companies have personalized our pens in order to surprise their clients, employees, or their sales force with an original, high-quality product. In combination to the pens it is also possible to personalize our Stifflexible notebooks and agenda books. For more information please see [www.stifflexible.it](http://www.stifflexible.it).

ALFA ROMEO SPA



ALFA WASSERMANN SPA







UNIVERSITÀ LUISS GUIDO CARLI



MASERATI SPA



OUR PRODUCTION OF  
PENS AND ACCESSORIES:

- Planning
- Lathing
- Anodic and/or chromium-plating
- Assembling





3•6•5<sup>®</sup>

**stifflexible<sup>®</sup>**  
made in italy



GIULIANO MAZZUOLI

WRITING TOOLS



Premium Brand Art Materials and Writing Instruments

236 Raceway Drive, Unit 5 • Mooresville, NC 28117

Phone 704.664.1427 • Toll-free 866.833.7797 • Fax 888.423.0036

[creativeartmaterials.com](http://creativeartmaterials.com)